



BLUFF
MANUFACTURING, INC.

PRODUCT CATALOG

- Yard Ramps
- Dock Boards
- Dock Plates
- Rail Boards
- Dock Levelers
- Wheel Risers
- Steel Platforms
- Crash Guard™ Safety Products
- Mezzanines
- Conveyor Crossovers
- Stairways, Landings, Ladders
- Cantilever Racks

800.433.2212

www.bluffmanufacturing.com

DOCK BOARDS

Fully-welded steel dock boards provide a safe ramp for powered vehicle applications. Selecting the proper Bluff product for your application will improve product life, safety, and loading efficiency. Review the **Dock Board Selection Guide** on p. 5 before ordering to ensure your product selection is correct.

STEEL DOCK BOARD Model SC

- Steel plate with welded steel curbs and locking legs.
- Designed for 3,000 to 4,000 pound capacity forklifts in light use applications.
- Lifting chains included. *Speedy Board*® option (p. 4) available.
- Capacity 10,000 and 13,000 pounds.
- Width of 60" and 72". Lengths from 36" to 72".



STEEL DOCK BOARD Model T

- All-welded steel construction, double bend design.
- Use with conventional, refrigerated, or container trailers, or for below dock conditions.
- Capacities from 15,000 to 40,000 pounds.
- Two four-hole pin pockets placed on each edge for flexible positioning.
- Board is held in position using two 1" stress-proof steel pins.
- Fold-down lifting loops. *Speedy Board*® option (p. 4) available.
- Widths from 60" to 96".



STEEL DOCK BOARD Model TFL

- Same basic design as the "T" dock board, but uses locking legs in lieu of steel pins.
- Fold-down lifting loops. *Speedy Board*® option (p. 4) available.
- Not recommended for below dock loading.

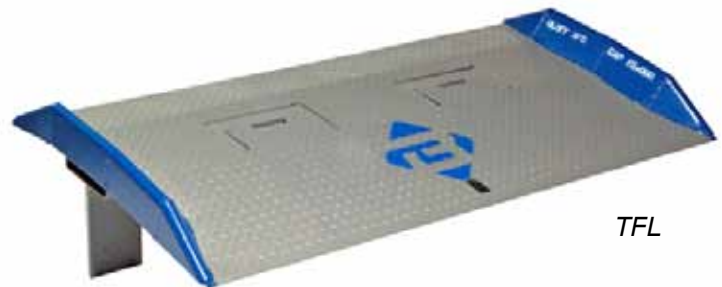

STEEL DOCK BOARD Model TNB

- Single-bend design utilizes the lifting chain and full width locking legs.
- Lifting chains included. *Speedy Board*® option (p. 4) available.)
- Not recommended for below dock loading.



Manufactured and tested in compliance with ANSI Standard MH30.2

DOCK BOARDS

RED PIN STEEL DOCK BOARD Model C

- All-welded steel construction.
- For difficult trailer-to-dock positions.
- Provide safe loading conditions for container and park-out applications.
- Dual-pin locking system with full length side pockets.
- Fold-down lifting loops. *Speedy Board*® option (p. 4) available.
- Capacities from 15,000 to 40,000 pounds.
- Widths from 60" to 96". Lengths from 48" to 120".

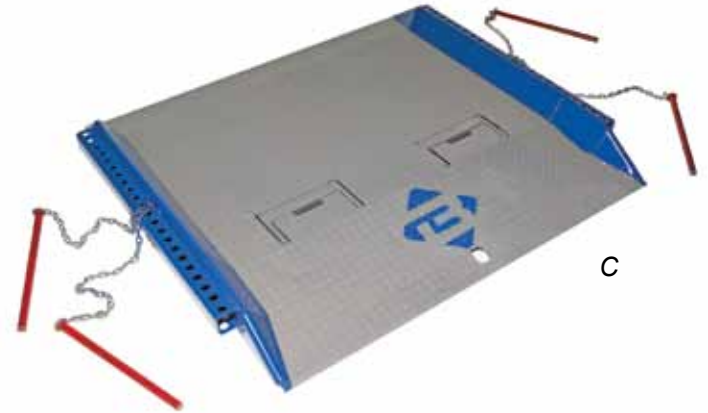

RAIL BOARD Model R

- All-welded steel construction.
- Capacities from 15,000 to 90,000 pounds.
- Rectangular or flared design.
- Box understructure for strength and safety.
- Heavy-duty locking rings for safe, secure positioning.
- Lifting loops fold flat into recessed pockets. *Speedy Board*® option (p. 4) available.
- Rail boards are custom designed and built to match the specific dock conditions. Worksheet required prior to manufacturing to ensure proper fit.
- Designed for use on all types of rail cars including refrigerated and special cars for the lumber and paper industries.

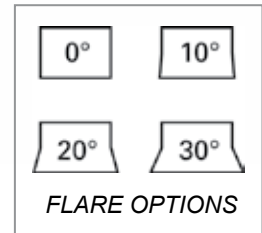

All rail board applications are factory quoted upon receipt of a fully completed Rail Board Worksheet.



RAIL BOARD PLACEMENT



LOCKING RING DESIGN



UNDERSTRUCTURE

Ask about the Options and Accessories available for Bluff Dock Boards

- *Speedy Board Cutouts*, p. 4
- *EZ Roll Handles*, p. 4
- *Lifting Chains*, p. 4
- *Lifting Loops*, pp. 2-3 (shown on Models T, TFL, & C)

Manufactured and tested in compliance with ANSI Standard MH30.2

DOCK BOARDS AND DOCK PLATES

Aluminum products are ideal for low to medium volume dock loading application. Aluminum is a great solution for coastal areas or the frozen food industry use where humidity and/or moisture is present. Bluff dock boards and dock plates are manufactured and tested in compliance with ANSI Standard MH30.2

ALUMINUM DOCK BOARD Models AC & BC

- Capacities from 10,000 to 15,000 pounds.
- Full-length structural steel bolt-on curbs for increased strength and to prevent runoff.
- Locking legs provide secure positioning.
- Standard lip length for conventional trailers is 11", option of 14" for refrigerated applications.
- Widths from 60" to 72", and lengths from 36" to 96".

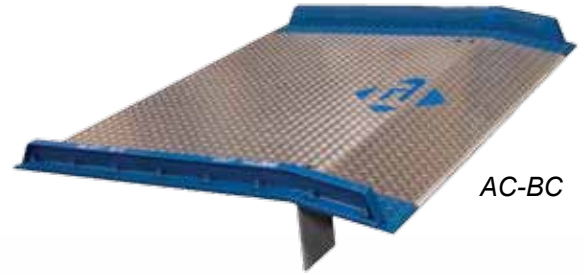

AC-BC

ALUMINUM DOCK BOARD Model ATD

Designed for light duty in low to medium volume applications with a forklift or pallet jack.

- Welded aluminum construction with extruded curbs and legs.
- Capacities of 10,000 and 15,000 pounds.
- Lengths ranging from 36" to 72".

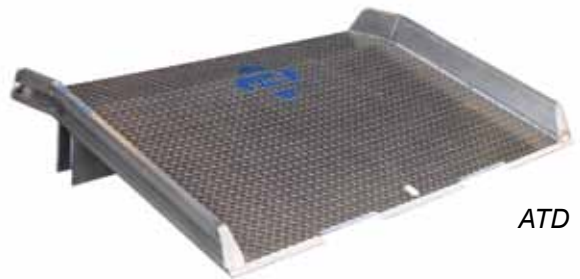

ATD

ALUMINUM SPRING LOADED DOCK PLATE Model SL Patent No. D633,684

- Recommended for loading applications involving hand trucks/dollies and pallet jacks.
- Top-of-dock mounted, vertically stored. Dual spring lift assist.
- Optional Kick Plates and Non-Skid Tape surface available.



SL

ALUMINUM DOCK PLATE Models A & B

- Recommended for light activity, non-powered loading applications.
- Bolt-on steel legs for securing position between the dock and the trailer.
- Standard lip length for conventional trailers is 11", option of 14" for refrigerated applications.
- Available in two capacity ranges. Wide range of sizes available.

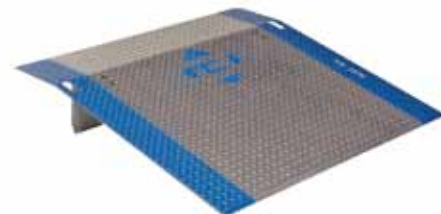

A-B

OPTIONS AVAILABLE

EZ-Roll Attachment: One person positioning without the use of a forklift. Telescoping handle stores away while board is in use.

Lifting Chains: For positioning of board by forklift.

Speedy Board® Cutouts: Allows the forklift driver the ability to move, place, and retrieve the board without exiting the forklift. For dock boards only.



DOCK BOARD SELECTION GUIDE

When making dock board and/or dock plate selections, you should consider the extremes rather than the averages.

CAPACITY

PLATES

- Weight of equipment and heaviest load.

BOARDS

- See chart:

CAPACITY SELECTION CHART		
4-Wheel Forklift Lifting Capacity	3-Wheel Forklift Lifting Capacity	Board Capacity Required
2,000 – 3,000	2,000	10,000
3,000 – 4,000	2,500	13,000
5,000	3,000 – 3,500	15,000
5,000 – 6,000	4,000 – 5,000	20,000

- Capacity rated for single-shift operation at a 3 mile per hour maximum rate of travel.
- Stackers and other narrow aisle loaders should not be used on a dock board.
- Paper roll clamp and multi-shift loading add 5,000 pounds to the board capacity.

LENGTH

To determine the proper length of a dock board/plate, three items are required:

1. Dock height (D)
2. Height of highest truck (T)
3. Gradability of loading equipment used.

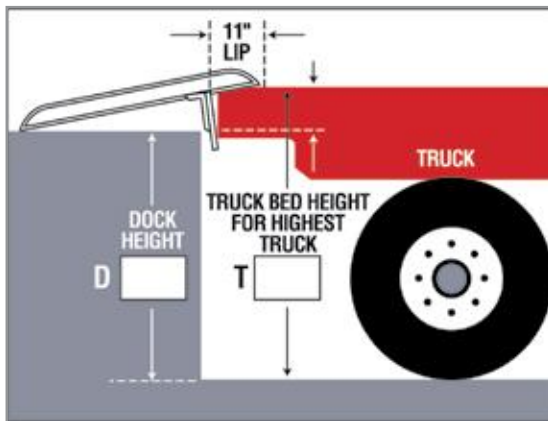

MAXIMUM TRAILER HEIGHT SERVED

Freight Line Trailers	46" - 56"
Flatbed Trailers	50" - 60"+
Bob Tail Trucks	46" - 48"
Containers	56" - 62"
Refrigerated Trailers	50" - 60"

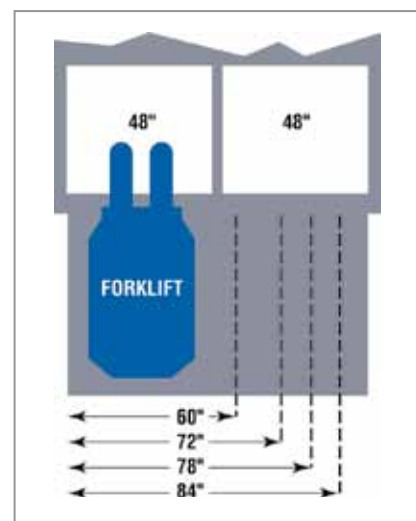

WIDTH

Bluff recommends a minimum product width of 12" to 18" wider than the overall width of the vehicle or pallet used. For improved end loading efficiency, you may consider increasing board width, as shown in the diagram (on right).

YARD RAMPS

A safe and cost effective answer to many loading dock issues. Yard ramps are typically used in ground-to-dock or ground-to-truck applications. Available with or without undercarriage.

STEEL YARD RAMP Model SYS

- All-steel welded construction.
- Capacities from 16,000 to 60,000 pounds. Wide range of sizes offered.
- Curbs 8" tall for safety and greater capacity.
- Double-acting hydraulic pump to adjust the unit to the proper position.
- Solid 18" rubber tires provide excellent traction without worry of puncture.
- Pneumatic tires optional.
- Beveled approach provides a smooth transition.
- 36' unit includes a level-off for unloading end pallets.
- 30' straight design for quick loading from dock to ground.
- Unit without undercarriage for permanent locations.
- Lip purchase into trailer is 16".
- Capacity of yard ramp selected must be greater than the combined weight of the heaviest forklift and the heaviest weight of anticipated loads it will carry.
- The width should be at least 15" wider than the widest equipment to be used on the ramp. Usable width is 6" less than overall width.



OPTIONS AND ACCESSORIES

- Ramp clamp or tow bar is included as standard equipment.
- Pneumatic tires are available for use on uneven surfaces.

MAXIMUM & MINIMUM SLOPES, LIP HEIGHTS, LIP LENGTHS

Length & Configuration	30' Straight	30' Level-Off	36' Straight	36' Level-Off
Wheel Diameter	18"	18"	18"	18"
Maximum Usable Lip Height	72"	63"	74"	67"
Percent of Grade	23%	23%	19.3%	19.3%
Degrees of Incline	13.0°	13.0°	10.9°	10.9°
Minimum Usable Lip Height	40"	32"	42"	33"
Percent of Grade	11.6%	11.8%	10.1%	9.2%
Degrees of Incline	6.2°	6.2°	5.3°	5.3°

YARD RAMP FEATURES AND OPTIONS

GIRDERS

- Heavy-duty formed steel side girders provide main load-bearing capability.
- Steel side girders welded to steel Z cross members form a superior frame.



GIRDERS

GRATING

- Self-cleaning, serrated grating provides excellent traction and the open design prevents build-up of water, snow, oil, grease, and miscellaneous debris.
- The lower end approach plate provides maximum support and smooth transition onto the ramp grating surface.
- **Note:** Grating not supportive of forklift turning maneuvers.



RAMPClamp

RAMP CLAMP

- Assists operator in moving the yard ramp over short distances.
- Forklift tine inserts into the swiveling lift loop and is secured by a locking device.

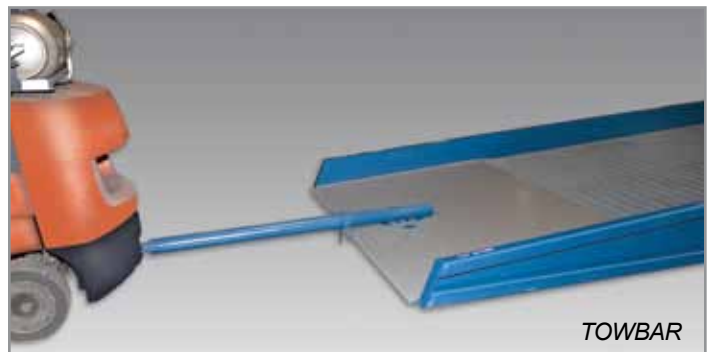

TOWBAR

TOW BAR

- Tow bar features a fast-locking, easy hook-up to the yard ramp and makes towing over longer distances practical.
- A quick disconnect feature improves handling efficiency.

HYDRAULIC PUMP

- Hydraulic system allows for smooth and quick raising of the front lip to the proper dock or trailer height.
- The pump is mounted internally to protect it from accidental damage.
- Double-acting.
- Two hydraulic cylinders.



HYDRAULIC PUMP



GRATING

DOCK LEVELERS

Bluff's Edge-of-Dock Levelers are used in dock to truck applications. Lo-Dock Levelers have a working range of 5" up or 5" down when using a gas or propane powered forklift. (3" up or 3" down when using an electric forklift).

EDGE-OF-DOCK LEVELER Model EP

- Positioned by lifting a self-storing handle and pulling the handle to the dock floor. (See illustration below.)
- Latch assembly activates the lip forward to the floor of the trailer as the handle is lifted.
- Automatically returns to stored position when truck leaves.
- Bumper and Bumper Blocks are included.
- Steel faced bumpers available.
- Capacities from 20,000 to 25,000 pounds.
- Widths of 66", 72" & 78".
- Refrigerated lip optional.

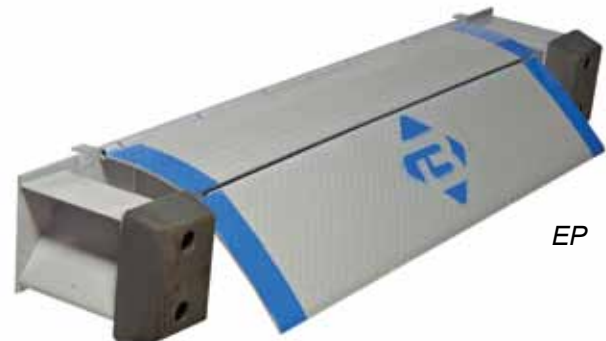

LO-DOCK LEVELER Model LD

- Raises Edge-of-Dock Levelers to proper working height.
- Working range of 5" above and 5" below dock.
- Raise present dock height as much as 11" without expensive alterations.
- Completely assembled; no site welding required.
- Easily installed on any concrete dock without welding or modifications.
- Because of gradability problems, dock levelers are not recommended for use with pallet jacks or stackers.
- Refrigerated lip is optional.
- Lo-Dock Leveler is available with Door Seal Option.

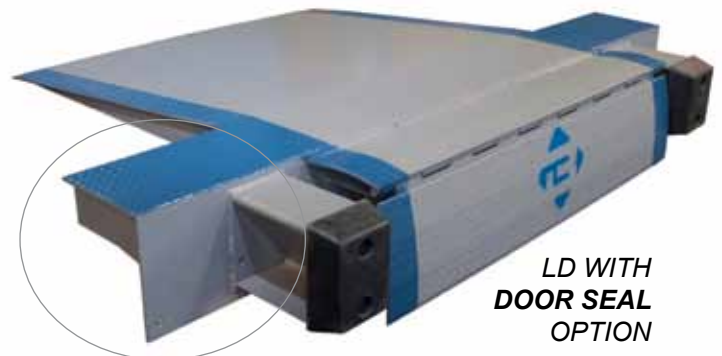
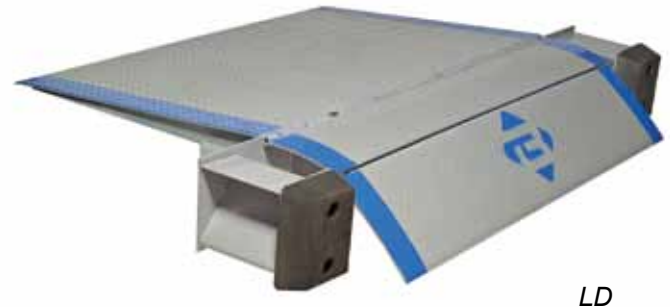

EDGE-OF-DOCK LEVELER WITH EZ PULL HANDLE

WHEEL RISERS & PLATFORMS

WHEEL RISERS

- Eliminate unsafe, below dock loading conditions.
- Reduce damage to loading equipment.
- Position trailers properly above dock for more efficient loading.
- Heights up to 12". Widths of 18" and 24".
- Lengths to accommodate both single, dual, or tandem axle trailers.
- Wheel risers can be portable or permanently positioned.
- Custom sizes available.

STEEL WHEEL RISERS Model SWR

- Tabs for anchoring

ALUMINUM WHEEL RISERS Model AWR

- Hand holds for easy moving.



SWR

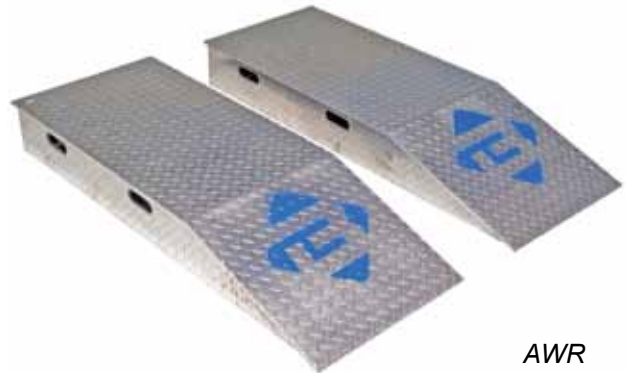

AWR

STEEL PLATFORMS Model SP

- Affords 90 degree turnability for safe forklift maneuvering.
- Fast, economical way to expand your dock area and increase freight handling capabilities without the expense of site or concrete work.
- Optional adjustable, telescoping legs of 44" to 55" allow elevations to meet most dock height requirements.
- Steel platforms can easily be relocated to other areas where a free-standing loading dock may be needed.



SP



YARD RAMP SHOWN WITH STEEL PLATFORM

CRASH GUARD SAFETY PRODUCTS

Improve plant safety and efficiency with Crash Guard™ by reducing the costs associated with employee injury, machinery down time, insurance claims, and building repairs due to accidental collisions.

TUFF GUARD SAFETY RAIL Model SRT

- Installs in minutes with ordinary hand tools and concrete drill.
- Formed 10 gauge steel rails in lengths up to 12'.
- Rails can withstand impacts of 10,000 pounds traveling at 4 miles per hour.
- Base plates are 8" square x 1/2" thick steel.
- Fasteners are included.
- Rounded top rails will prevent injuries and provide added personnel protection.

Original Crash Guard design available. Call for information.



SRT

MODULAR PROTECTIVE BARRIER Model MPB

Model MPB

- Inexpensive and simple answer to solving difficult safety barrier protection problems in your plant.
- Simple to install, add-on or customize guardrail lengths in the field.
- Light-weight "lift out" design allows temporary access to specific areas quickly and safely
- 42" double guardrail meets OSHA guidelines for fall protection.
- Formed 11 gauge steel rails in lengths up to 10'.
- Installation hardware not included.



MPB

BOLLARD Model SRB

- Protect personnel, machinery and structures.
- Simply bolt into position—no concrete work required.
- 6" I. D. sch 40 pipe.
- 42" high.
- 10" x 10" x 5/8" base.
- Plastic Cap.
- 3/4" mount holes.
- 5/8" anchors provided



SRB

CRASH GUARD SAFETY PRODUCTS

DOOR TRACK PROTECTORS Model DG

- Protects overhead door tracks from damage, reducing overall maintenance costs.
- Chamfered edge reduces risk of hand injury when lowering door.
- Wrap-around track design allows free door operation.
- Columns are 3/16" thick steel.
- Model DG base plate is 3/8" thick steel with three 5/8" holes (fasteners not included). Model DG-3 base plate is 1/4" thick steel with three 5/8" holes (fasteners not included).



DG



DG-3

POST PROTECTOR Model PO

- Various thickness protections available in 1/4", 3/8" and 1/2".
- Height protection available in 12", 18" and 24".
- Standard models fit around rack posts up to 4" wide.



PO



RG

RACK GUARD Model RG

- A simple and inexpensive way to absorb fork truck impact that can damage pallet rack uprights and valuable product.
- Heavy duty design.
- Wrap-around feature protects rack from both front and aisle damage.
- Bolted to floor for extra stability.

MACHINE GUARD Model MG

- Fully welded unit creates barriers between traffic areas and valuable machinery
- Heights available in 10", 24", and 42" sizes
- 4" square steel tubing with 1/2"x 8"x 8" base plates
- 5" square steel tubing comes with 1/2"x10"x 10" base plates
- Quick and easy installation



MG



Safety Yellow



Gloss Orange



Red Letter



Blue Ribbon



Campus Green



Gloss Black

All Crash Guard Safety Products come standard with a Safety Yellow powder coat finish. Available in six standard colors, custom colors, and galvanized finish.

MEZZANINES

MEZZANINE STRUCTURES

- Non-welded bolt connections and flexibility of design allow for future modifications, relocation and/or expansion and potential reconfiguration.
- Equipment and machinery mounting options available; multi-tiered integration of existing structures.
- Maximization of vertical clearance for exceptional under-mezzanine space utilization.
- High quality design and standardization of components to keep installation costs down.
- Built to last and backed with a lifetime structural warranty.



General Mezzanine Specifications

- Free-standing, pre-fabricated structure. Requires no on-site welding.
- Registered Structural Engineer to supervise or approve all designs and details.
- Engineering (PE) seal on final drawings where applicable.
- Pre-fabrication drawings submitted for approval.
- Structural design in accordance with the American Institute of Steel Construction (AISC) Manual of Steel Construction.
- Joist Construction performed in accordance with the Steel Joist Institute (SJI).



There are several options available for decking. Special options include swing gates, stairways and work platforms, drop plates, custom openings, horizontal handrails and conveyor support systems.

CONVEYOR CROSSOVERS AND STAIRWAYS

CONVEYOR CROSSOVERS

Bluff's goal is to provide you with crossover solutions which maximize the efficiency of your operations and minimize the costly potential of injury by keeping your personnel safe.

Conveyor Crossover Specifications

- Welded steel construction for longer life cycle and lower maintenance costs.
- Customization of capacities and configurations, specific widths and vertical clearances.
- Alternate configurations including U-shaped, Z-shaped and L-shaped with intermediate landings where necessary.



STAIRWAYS

Bluff starts its product planning with an assessment of your stairway application needs. Our professional engineers then develop a plan which can either be integrated into your existing installation or can be a new, freestanding installation. All stairways systems are IBC, UBS and OSHA compliant.

Stairway Specifications

- 36" standard width. Customization available.
- Tread options: bar grate or diamond plate.
- Closed risers.
- Custom sizes and configurations: straight, L-Shaped and U-shaped runs with intermediate landings.
- Stair tower systems are designed to meet your exact height and space requirements.
- Standard stairway consists of 3 parts: 2 stringers with welded handrail and grip rail; treads bolted between stringers.



LANDINGS AND LADDERS

LANDINGS

If you have a vertical rise exceeding 12 feet, you must have an intermediate landing. Bluff will actively work with you to design and develop the most functional and efficient stair system possible within your space constraints. Landings can be provided with stairs or sold separately.

Landings Specifications

- Fixed handrail in compliance with applicable code
- Gate options for platform landing
- Custom sizes and configurations (straight, L-shaped and U-shaped runs)
- Top landings available for specific ingress/egress requirements
- Choice of decking material



LADDERS

Design applications include simple fixed ladders, caged and uncaged ladders as well as ships ladders. All Bluff ladders are designed and constructed in compliance with OSHA and ANSI Standards.

Straight Ladders

- All-welded steel.
- Require caging when heights exceed 20'.
- Intermediate landing requires when over 30'.
- Rungs are 3/4" serrated round rebar.
- Handrail extends 42" above top rung.

Ships Ladders

- Bolted steel.
- No caging requirements.
- Intermediate landing required when over 12'.
- Tread depth of 6", width up to 36".
- Ladder with 36" grip rail, handrail 42" above top tread.
- Three piece construction consisting of 2 stringers with welded grip rail and bolted treads.



CANTILEVER RACKS

CANTILEVER RACKS

- Minimize footprint of storage space while maximizing vertical and horizontal space usage.
- Capitalize on the higher lifting capacity and operational capability of current lifting equipment.
- Reduce handling time and enhance efficiency of inventory control/management through improved accessibility to storage space.
- Minimize cost of damaged product from storage structure obstacles.

Arms

- The capacity of a cantilever rack is based on the upright height and the length of the arms.
- Cantilever arms are either straight (used for stable loads such as lumber, steel sheets, cartons, etc.) or inclined (used for cylindrical objects or loads which tend to roll forward).
- Arms are completely adjustable on 4" centers. Arms are welded to a mount plate which is then bolted to the upright.

Upright Column

- Upright column height takes into consideration the limitations of ceiling height and ceiling conditions such as sprinkler system, lighting fixtures, etc. as well as the reach of your lifting equipment.
- High strength steel columns are either Single-Sided or Double Sided and range in height from 8' to 20'
- Columns are pre-punched with 4" centered arm mounting holes.

Cantilever Base

- Cantilever base has a factory option of either being completely welded construction or bolt on construction. Both options provide a stable, rigid base connection.

Brace

- Bracing between uprights allows for continuous rows for longer stock and for uninterrupted.

Options

- Material Tray – used as a product pan for loosely stored items of varying sizes.

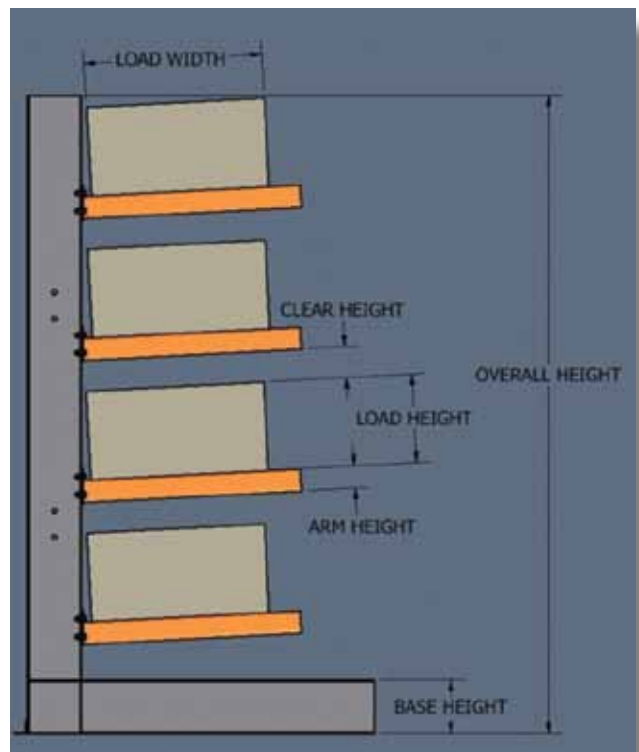

- **Since 1968, the proven leader in quality dock and warehouse equipment**
- **Short lead times on manufactured items**
- **99% on-time shipping**
- **Responsive sales support team**
- **Marketed through material handling dealers**
- **Quick ship items stocked in regional warehouses**



- ATLANTA, GA
- CHARLOTTE, NC
- CHICAGO, IL
- CINCINNATI, OH
- FORT WORTH, TX
- HOUSTON, TX
- LOS ANGELES, CA
- N. ARLINGTON, NJ
- SAN LORENZO, CA
- SEATTLE, WA
- ST. LOUIS, MO
- TAMPA, FL



9201 South Freeway • Fort Worth, Texas 76140 • 800-433-2212
www.bluffmanufacturing.com